

The original, award-winning universal window and door restrictors

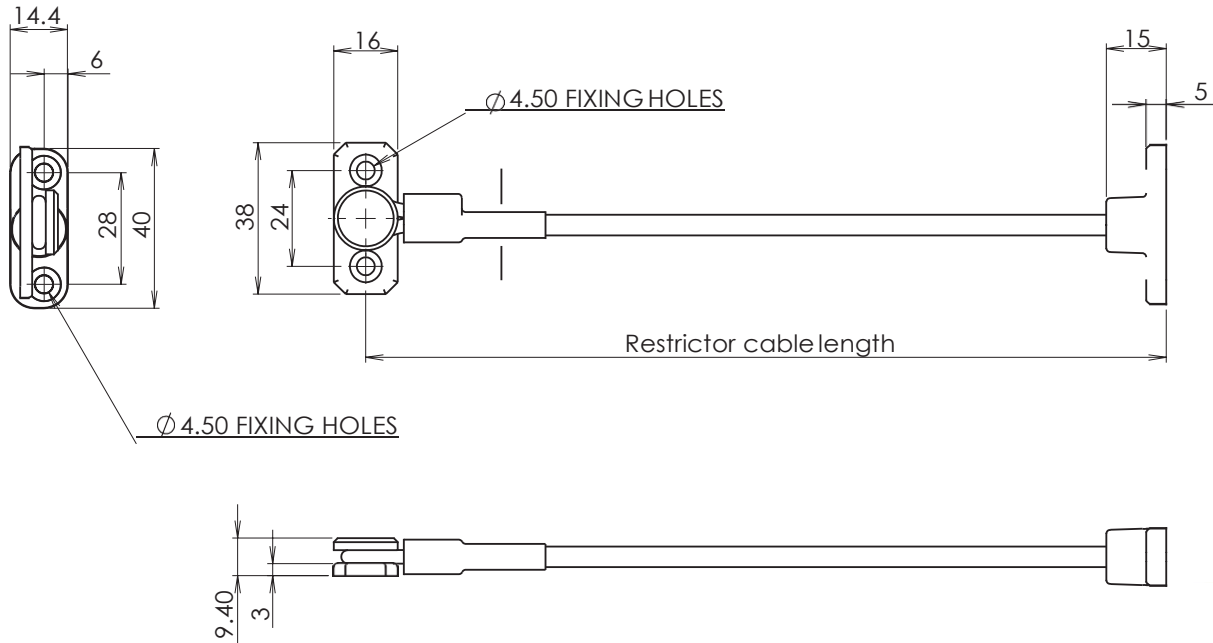

SAFETY AT EVERY LEVEL

Jackloc Perma cable window restrictor



All dimensions in mm

FEATURES

- For applications requiring a permanently-fixed window restrictor
- Designed to reduce the risk of falls from windows
- Can be fitted to most styles of windows and doors
- Can be fitted to uPVC, wood, aluminium, steel and composite materials
- Standard cable length of 200mm
- Four, hardened and coated security clutch-head screws

STANDARD OPTIONS

- Standard colours available:
 1. White with a white cable sleeve
 2. Brown with a black cable sleeve
 3. Black with a black cable sleeve

TESTS

- **BS EN 13126-5: 2011** - Independently tested and passed
 - Opening Test – Jackloc Perma restrictor achieved a pass and the Jackloc continued to operate normally after the test.
 - Durability Grade Cycles – the Jackloc achieved a pass and met grade three as specified in the standard.
 - Mechanical Load – the Jackloc achieved a pass of this standard and showed no sign of wear after the test.

Jackloc requested an additional load of 1,600N be applied and the restrictor passed – although this is not a requirement of the standard.

- Percussion Test – a metal pendulum hammer was set to give the most severe impact on the Jackloc as per this standard. The pendulum arm was set so that a fall angle of 45% was achieved and the Jackloc was subjected to three percussions of the pendulum hammer. The Jackloc passed the test and showed no signs of wear after the test.
- Impact Test – a 50kg double-tyre impactor was dropped from the required grade drop height and impacted the centre of the window sash. The Jackloc achieved a pass at grade two.
- Cutting Test – the Jackloc Swivel/Stud cable was mounted onto the cutting test block and placed into the security test rig. The Jackloc restrictor was mounted to the fixed base of a stamping tool and a force of 10N applied throughout the test to keep the cable taut. The punch was rested onto the cable and a force of 100 N/s until a force of 3,600N was achieved.
- The Jackloc Perma window restrictor as tested conforms to Safety in use – Grade 3 and Application Grade–5/7 as Child Safety Holding Restrictor according to table 2 of BS EN 13126-5:2011.

Jackloc Perma cable window restrictor

IMPORTANT

The high-performance Jackloc Perma window restrictor can be fitted to all conventional windows, materials and styles with several options of fixings and anchorage when installing.

Each installation project must be surveyed and evaluated prior to fitting the Jackloc Perma window restrictor in order to determine the appropriate fixings/anchorage and to achieve the restrictor opening to a maximum of 100mm or a maximum opening of 89mm to prevent the passage of a child in accordance to BS EN 13126-5:2011.

The Jackloc Perma can be fitted either vertically or horizontally. The Jackloc is supplied with Size 8 security clutch screws and once fitted, they cannot be unscrewed. If a different fixing is preferred, please refer to the window manufacturer.

Great care must be taken to inspect each and every window to verify that they are in a sound, serviceable condition and to ensure the secure fitting of the Jackloc window restrictor.

The Jackloc Perma restrictor must not be fitted to areas of decaying timber, corroding steel or any materials that are in disrepair.



IMPORTANT: it is important to position Part A and B prior to fixing in order to determine the window fixed opening.

- A maximum of 100mm or a maximum opening of 89mm to prevent the passage of a small child in accordance to BS EN 13126-5:2011.
- Fit Part A (Stud footplate) to the fixed frame and Part B (swivel-cable foot plate) to the opening window frame.
- To fit, place Part A in the desired position on the window frame and mark the screw holes. It is advisable to drill pilot holes with a 3mm drill bit. Repeat for Part B on the opening window frame, making sure the opening will not be greater than specified above. Ensure the window is closed during fitting.
- Once fitted, pull on the cable and make sure that there is no movement of the swivel and stud footplates to confirm it is securely fitted.

NOTE: This is a permanent restrictor when fitted with the supplied security screws.

JACKLOC MAINTENANCE

1. Clean footplates and cable occasionally with a damp cloth only.
2. Frequently check the Jackloc Swivel/Stud footplate fixings (Parts A and B) by manually identifying any excessive movement of the screw fixings. Should there be excessive play, remove the screws. Assess the failure of the fixing(s) and refit appropriate screws or bolts. In some instances, die tap back plates and screws may have to be used.
3. Treat the Swivel/Stud footplates with PTFE or other approved lubricant at least every six months.
4. Check the anchorage of the linkage into the swivel and stud footplates by pulling the cable manually. If there is excessive movement of the cable within the anchorage plate, replace the complete linkage with new.



SAFETY AT EVERY LEVEL

The Jackloc Company Ltd
Alma Park, Woodway Lane, Claybrooke Parva, Lutterworth,
LE17 5BH United Kingdom

sales@jackloc.com

Tel: +44 (0)1455 220 616 Fax: +44 (0)1455 220 565

www.jackloc.com

Engineered and Manufactured in the UK in accordance with an accredited ISO 9001 quality System, ISO 14001 Environmental Management and OHSAS 18001 Occupational Health and Safety

Registered Office: Registered in England and Wales company number 04890609
Alma Park, Woodway Lane, Claybrooke Parva, Lutterworth, LE17 5BH

