

The original, award-winning window and door restrictors

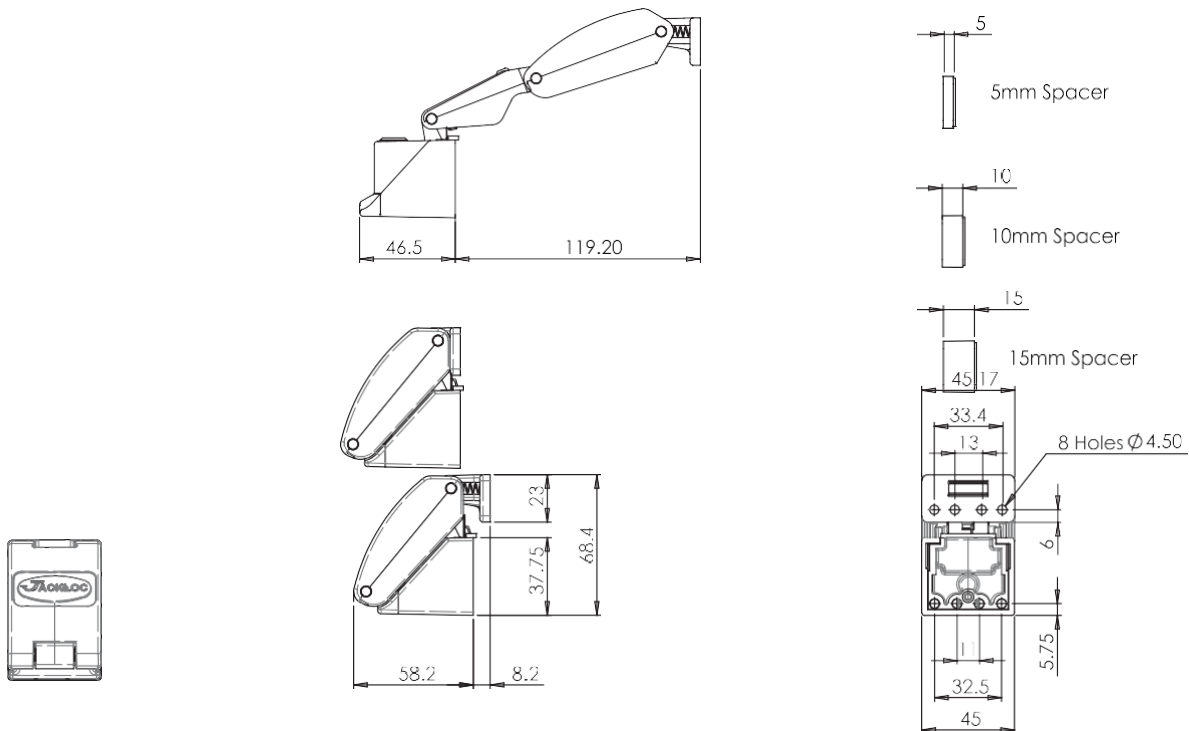

Titan by Jackloc Folding Window Restrictor SAFETY AT EVERY LEVEL



All dimensions in mm

FEATURES

- Designed to reduce the risk of falls from windows
- Fit to Side hung or top hung windows
- Five disk locking barrel with key
- Heavy duty & Security approved
- Hardened and coated security clutch screws
- 3 packers to achieve an opening of 89mm or 100mm

STANDARD OPTIONS

- White
- Brown
- Black

INDEPENDENT TEST APPROVALS

- UKAS BS EN 14351-1:2006
Titan by Jackloc window restrictor was tested on an aluminium top hung window 1200 x 1200mm. The test passed the required 350 newtons.
- BS EN 13126-5:2011 +A1:2014
Jackloc robust folding window restrictor was tested on an aluminium top hung window 1200 x 1200mm in conjunction with the standard.
- SOLD SECURE – SS301:2015
Domestic buildings - bronze.

- Opening Test – Jackloc folding restrictor achieved a pass and the Jackloc continued to operate normally after the test.
- Durability Grade Cycles – The Jackloc achieved a pass and met the highest grade of five as specified in the standard.
- Restrictor Strength Test – The Jackloc with the window open and the restrictor engaged, a force of 350N was applied to the sash in the direction of opening at the centre of the window opening edge. The force was held in place for 60 seconds before being removed – the Jackloc achieved a pass.
- Static Load Test – With the window open and the restrictor engaged, a force of 200N was applied to the sash at a position and direction to apply the most strain to the restrictor. The force was held in place for 60 seconds and passed. The Jackloc continued to operate normally after the test.
- Impact Test – With the window open and the restrictor engaged, the window was subject to an impact in accordance with the methodology defined in BS EN 13049:2003. A 50kg double tyre impactor was dropped from the required grade drop height and impacted the centre of the window sash. The Jackloc achieved a pass at grade two.

The restrictor was further tested to grade 3 (430mm) where upon the window failed. The restrictor continued to operate normally.

Titan by Jackloc Folding Window Restrictor

IMPORTANT

The high-performance Titan by Jackloc window restrictor can be fitted to side hung and top window types of different materials with options of fixings and anchorage.

Each installation project must be surveyed and evaluated prior to fitting the Titan by Jackloc window restrictor to determine the appropriate fixings/anchorage and to achieve the restrictor opening to a maximum of 100mm or a maximum opening of 89mm to prevent the passage of a child in accordance to BS EN 13126-5:2011 + A1:2014.

The Titan by Jackloc window restrictor can be fitted either vertically or horizontally and is supplied with three different size spacers of 5mm, 10mm and 15mm to use independently or grouped to accommodate any open voids between the fixing of the restrictor to casement/outer frame. A total of 8 security clutch screws - once fitted, they cannot be unscrewed. If different fixings are preferred, refer to window manufacturer.

IMPORTANT: Please refer to window manufacture for fixing types before fitting the Titan by Jackloc restrictor.

The security screws supplied are No 8. Countersunk.

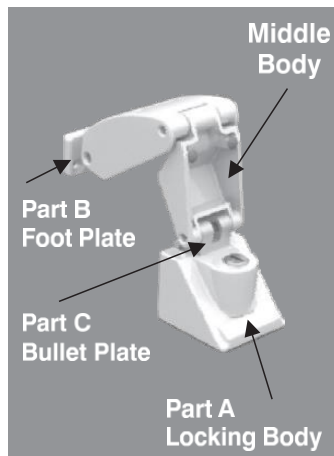

Locking Body – Part A

- 4 x 40mm screws for fixing locking body to the casement or outer frame.

Footplate - Part B and Spacers

- 4 x 25.4mm screws for fixing footplate on its own or with the 5mm spacer.
- 4 x 40mm screws for fixing the footplate with either spacer to 15mm (can be spacer 5mm and 10mm together, or the 15mm).
- 4 x 55mm screws for fixing the footplate and all spacers (spacer 5mm, 10mm and 15mm).



SAFETY AT EVERY LEVEL

The Jackloc Company Ltd
Alma Park, Woodway Lane, Claybrooke Parva, Lutterworth,
LE17 5BH United Kingdom

sales@jackloc.com

Tel: +44 (0)1455 220 616 Fax: +44 (0)1455 220 565

www.jackloc.com



Engineered and Manufactured in the UK in accordance with an accredited ISO 9001 quality System, ISO 14001 Environmental Management and OHSAS 18001 Occupational Health and Safety

Registered in England and Wales company number 04890609
Registered Office: Alma Park, Woodway Lane, Claybrooke Parva, Lutterworth,
Leicestershire, LE17 5BH, United Kingdom

Great care must be taken to inspect each and every window to verify that they are in good sound and serviceable condition to ensure the secure fitting of the Jackloc restrictor. The Titan restrictor must not be fitted to areas of decaying timber, corroding steel or any materials that are in disrepair.

IMPORTANT: it is important to position Part A and B prior to fixing in order to determine the fixed casement window opening conforms to the mandatory and/or legislated Directives.

Fit Part A (locking body) to the fixed frame and Part B (foot plate) to the opening casement. – To fit, place Part A in the desired position on the window frame and mark the screw holes with a bradawl. It is advisable to drill pilot holes with a 3mm drill bit. Repeat for Part B on the opening window frame, making sure the opening will not be greater than specified on the front page of the instructions. Ensure the window is closed during fitting.

To operate the Titan, ensure that the bullet Plate (Part C) is pushed into the unlocked body of Part A, then turn the key to the locked position. The key will only depart the locking body when in the locked position. – Pull on the Middle Body to confirm it is secure.

NOTE: The bullet plate can only be removed when the key is in the unlocked position. The key must be used to re-lock the restrictor.

JACKLOC MAINTENANCE PROCEDURE

1. Clean body and all component parts occasionally with a damp cloth only.
2. Frequently check the Jackloc body fixings (Parts A and B) by manually identifying any excessive movement of the screw fixings. Should there be excessive play, remove the metal cover cap of part A and remove screws of Part A and Part B.

Assess the failure of the fixing(s) and refit appropriate screws or bolts, etc. In some instances, die tap back plates and screws may have to be used. Refit metal cap of part A.
3. Frequently check that the key lock and springs operate correctly and spray PTFE or other approved lubricant into the barrel lock as necessary, or to six-month intervals (whichever is the shorter). With locks and springs located within a marine or heavily-polluted environment, this inspection interval should be shortened to at least every three months.